



CREATING A CLEANER, SAFER, HEALTHIER WORLD.

EQUIPMENT



# 8300

## BATTERY-POWERED SWEEPER SCRUBBER

- Just-scrubbed floors left clean, dry and safe for traffic in seconds with ec-H2O™ or FaST® technology
- Delivers unlimited, fume-free operation with virtually continuous battery power
- Enhances productivity by effectively sweeping and scrubbing at the same time

## MULTI-TASKING WORKHORSE PROVIDES EFFORTLESS, ONE-PASS CLEANING



### EXCELLENT SCRUBBING PERFORMANCE

MaxPro™ Scrubbing Technology maintains consistent down-pressure on brushes for better cleaning performance and longer brush life.

### THE SAFEST WAY TO CLEAN

Increase safety and cleanliness with chemical-free ec-H<sub>2</sub>O™ or FaST® Foam Technology. The 8300 uses up to 70% less water with both technologies. ec-H<sub>2</sub>O is chemical-free and uses no detergent, while FaST uses up to 90% less detergent.

### EASY TO USE

One-button operation plus simple, no-tool access to the battery, brushes and squeegee system makes the 8300 easy for operators.

### MUST-HAVE OPTIONS

#### **Extend your cleaning reach**

Dual side brushes create a 64 in / 1630 mm cleaning path for world class productivity.

#### **Industrial performance**

Add productivity and versatility with a squeegee wand.

#### **Increase productivity up to 3 hours**

Dramatically extend cleaning time, even when cleaning porous concrete, by continually filtering and recycling recovered solution with the ES® system.

INSIDE THE

# 8300

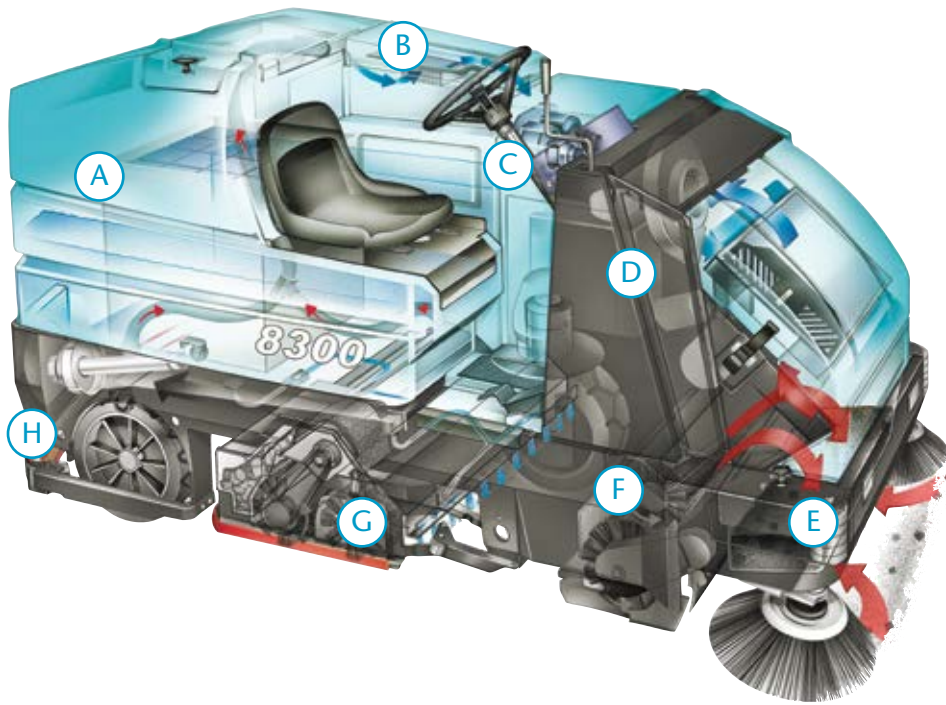

- A** **Extended run-time** from large capacity batteries.
- B** **No-mess clean-up** from large, easy-access recovery tanks.
- C** **Operator comfort** is maximized with standard power steering.
- D** **Maximize productivity** with ec-H2O, FaST, or ES technology.
- E** **Productivity is increased** via 300 lb / 136 kg capacity "smart-hopper."

- F** **Patented MTS™ (Multi-Technology Sweeping) system** delivers excellent direct-throw sweeping performance: a re-directional cylinder sweeps debris into the hopper without brush carry-over.
- G** **Customize to exact specifications** with cylindrical or disk brushes.
- H** **Break-away, parabolic, no-tool change squeegee** with alarm for quick maintenance.

## EXCLUSIVE TECHNOLOGIES (optional cleaning innovations)

Both technologies increase scrub time up to three times using a single tank of water.



**ec-H2O technology** electrically converts water into an innovative cleaning solution that cleans effectively, saves money, improves safety, and reduces environmental impact\* compared to daily cleaning floor chemicals and methods.

\* Based on a study by EcoForm™. Visit [www.tennantco.com](http://www.tennantco.com) for more information.



**FaST Foam Scrubbing Technology** uses up to 70% less water and 90% less chemicals to improve floor traction as certified by NFSI, helping reduce the risk of slip and fall accidents.



**ES® Extended Scrubbing** productivity enhancement system recycles cleaning chemicals to increase uptime and improve productivity by scrubbing floors using 66% less chemicals than traditional cleaning methods.

## ENVIRONMENTAL STEWARDSHIP



ec-H2O™ and FaST® technologies are NFSI (National Floor Safety Institute) Certified. NFSI certified products must pass a 2-phase wet slip resistance process and have been shown to reduce the potential for slip-and-fall accidents.



ec-H2O and FaST technologies are registered by NSF International. NSF International is an independent, not-for-profit organization that ensures formulation and labels on these products meet appropriate food safety regulations.



ec-H2O and FaST technologies may contribute to LEED or LEED-EBOM (Existing Building: Operations & Maintenance) points, provided other appropriate criteria are met. For more information on obtaining LEED points, please contact your sales rep or refer to the USGBC website at: [www.usgbc.org](http://www.usgbc.org).



FaST is a Green Seal (GS-37) Certified Detergent. Green Seal evaluates and certifies cleaning products based on criteria such as the toxicity of the product, skin and eye irritation, skin sensitization, combustibility, toxicity to aquatic life, and packaging.



Conserve Resources



Reduce Detergents



Increase Safety



Improve Air Quality



Reduce Noise

Choose GE Capital or U.S. Bancorp, our leasing providers, for simple, quick financing with flexible upgrade options.

## 8300 BATTERY-POWERED SWEEPER SCRUBBER

### SWEEPING SYSTEM

Cleaning path	
Single side brush (RH Side)	50 in / 1270 mm
Dual side brush	64 in / 1630 mm
Main brush length	36 in / 920 mm
Brush motor	0.8 hp / 0.60 kW
Hopper volume capacity	3 ft <sup>3</sup> / 85 L
Hopper weight capacity	300 lbs / 136 kg
Hopper dump height	60 in / 1530 mm

### SCRUBBING SYSTEM

Cleaning path	
MaxPro™ 1000 scrubhead	40 in / 1020 mm
MaxPro™ 1200 scrubhead	48 in / 1220 mm
Edge scrub reach	5 in / 130 mm
Solution tank	57 gal / 216 L
Demisting chamber	17 gal / 64 L
Solution recycling tank (ES Option)	90 gal / 340 L
Disk scrubhead	
Brush speed	320 rpm
Brush down pressure (variable to)	500 lb / 227 kg
Brush size (2) MP1000 diameter	20 in / 510 mm
Brush size (3) MP1200 diameter	16 in / 410 mm
Brush motor (2) MP1000 and (3) MP1200	1 hp / 0.75 kw
Cylindrical scrubhead	
Brush speed	500 rpm
Brush down pressure (variable to)	500 lb / 227 kg
Brush size (2) diameter	9 in / 230 mm
Brush Motor (2)	1.5 hp / 1.1 kW

### RECOVERY SYSTEM

Recovery tank	74 gal / 280 L
Vacuum fan speed	14,000 rpm (each of 2)
Vacuum water lift	65 in / 1650 mm
Vacuum fans (2)	0.85 hp / 0.63 kW

### PROPELLING SYSTEM

Propel speed forward (variable to)	5.5 mph / 8.8 km/hr
Propel speed reverse (variable to)	3.0 mph / 4.8 km/h
Propel motor	4.6 hp / 3.4 kW
Gradeability	
Transport at gross weight	8° / 14%
Working (Sweeping/Scrubbing)	6° / 10.5%
Ground Clearance (Transport)	2 in / 50 mm
Tires Front (1), Solid	6 in x 16.25 in / 150 mm x 410 mm
Tire Rear (2), Solid	5.0 in x 16 in / 130 mm x 410 mm

### WARRANTY

See your local representative for warranty information

Specifications subject to change without notice.

## SEEING IS BELIEVING

For a demonstration or additional information, call +1.800.553.8033 or email [info@tennantco.com](mailto:info@tennantco.com)

Tennant  
701 North Lilac Drive  
Minneapolis, MN 55422 USA

USA/Canada: +1.800.553.8033  
Quebec: +1.800.361.9050  
Overseas: +1.763.540.1315

1.017.001.am.en 8300 Brochure 9/13

©2013 The Tennant Company logo and other trademarks designated with the symbol "®" are trademarks of Tennant Company registered in the United States and/or other countries. Tennant Company's products are sold and serviced through subsidiaries of Tennant Company and distributors. All rights reserved.

[www.tennantco.com](http://www.tennantco.com)  
[info@tennantco.com](mailto:info@tennantco.com)